

PARTS LIST		
ITEM	QTY	PART NUMBER
1	1	42 X 48
2	1	44 X 48
3	1	42 X 48 FAN AND LIGHT
4	4	42 TRIM
5	2	HORIZONTAL PLENUM
6	2	VERTICAL PLENUM
7	6	19.75 DIVIDER
8	1	79.75 DIVIDER
9	1	FIRE GAURD
10	2	42 X 84
11	1	FRONT GUARD
12	2	SIDE GUARD

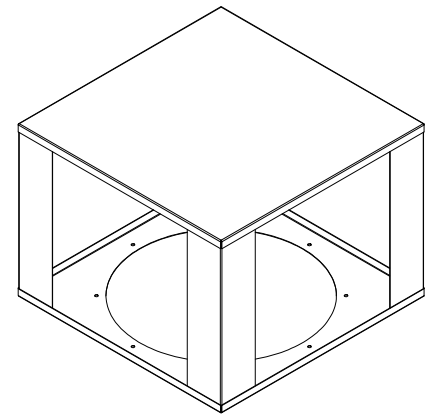

DIFFUSER ASSEMBLY

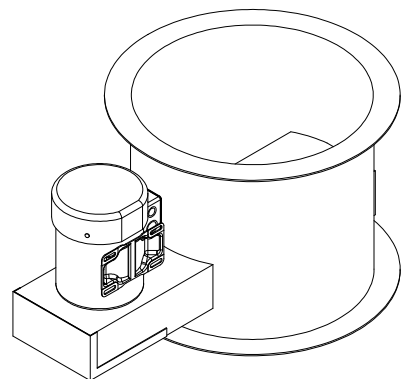

18" TUBE AXIAL FAN WITH TEFC MOTOR

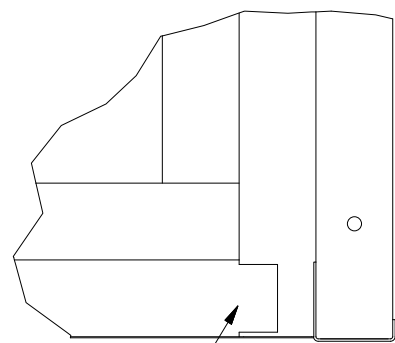

HORIZONTAL PLENUM PANEL OVERLAPS VERTICAL PANEL AND IS ATTACHED WITH SELF DRILLING SCREWS

DETAIL A SCALE .2

**PLENUM COSIST OF:**

- 2 - HORIZONTAL PLENUM PANELS
- 2 - VERTICL PLENUM PANELS
- 1 - 79.75 "T" DIVIDER
- 6 - 19.75 "T" DIVIDER

PLENUM PANELS ARE FASTENED TO SIDE WALLS 24.00" FROM REAR WALL USING SELF DRILLING SCREWS. FASTEN DIVIDERS TO PLENUM PANELS SPACING DIVIDERS APART 20.00 ON CENTER.

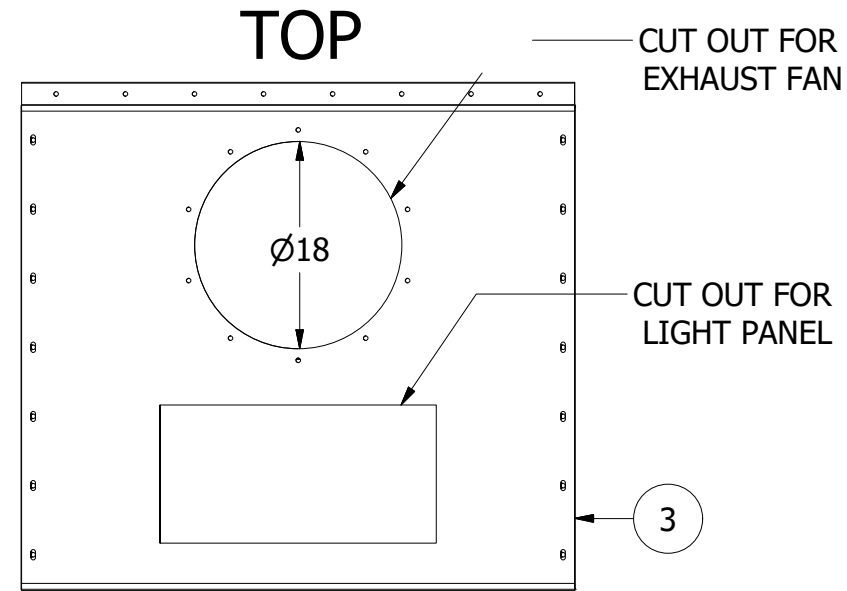

**FRONT**

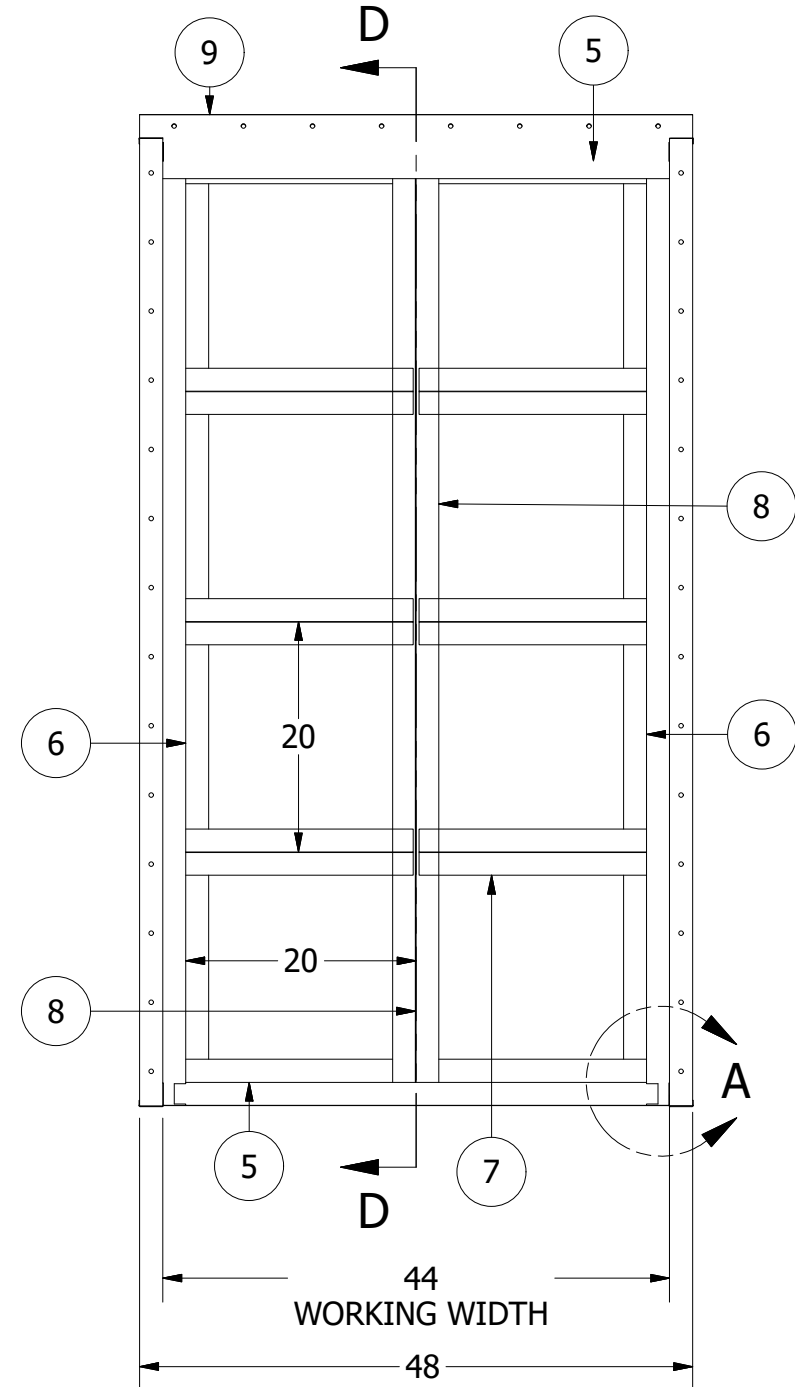

**RIGHT**

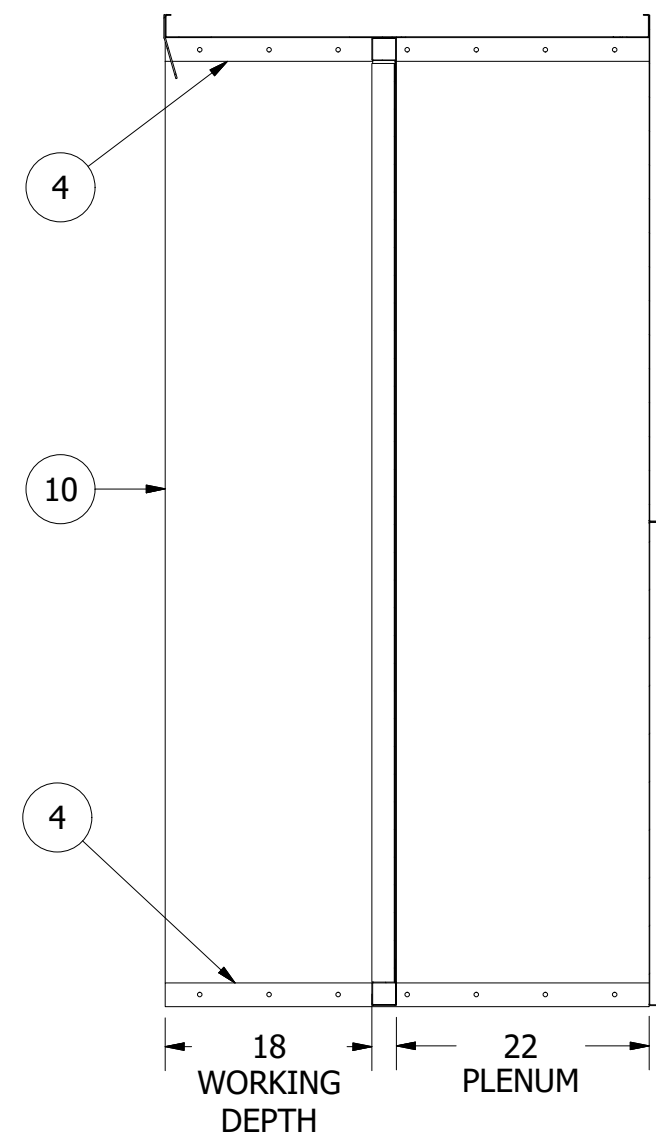

SECTION D-D SCALE .06

OPTIONAL ELECTRICAL GUARD

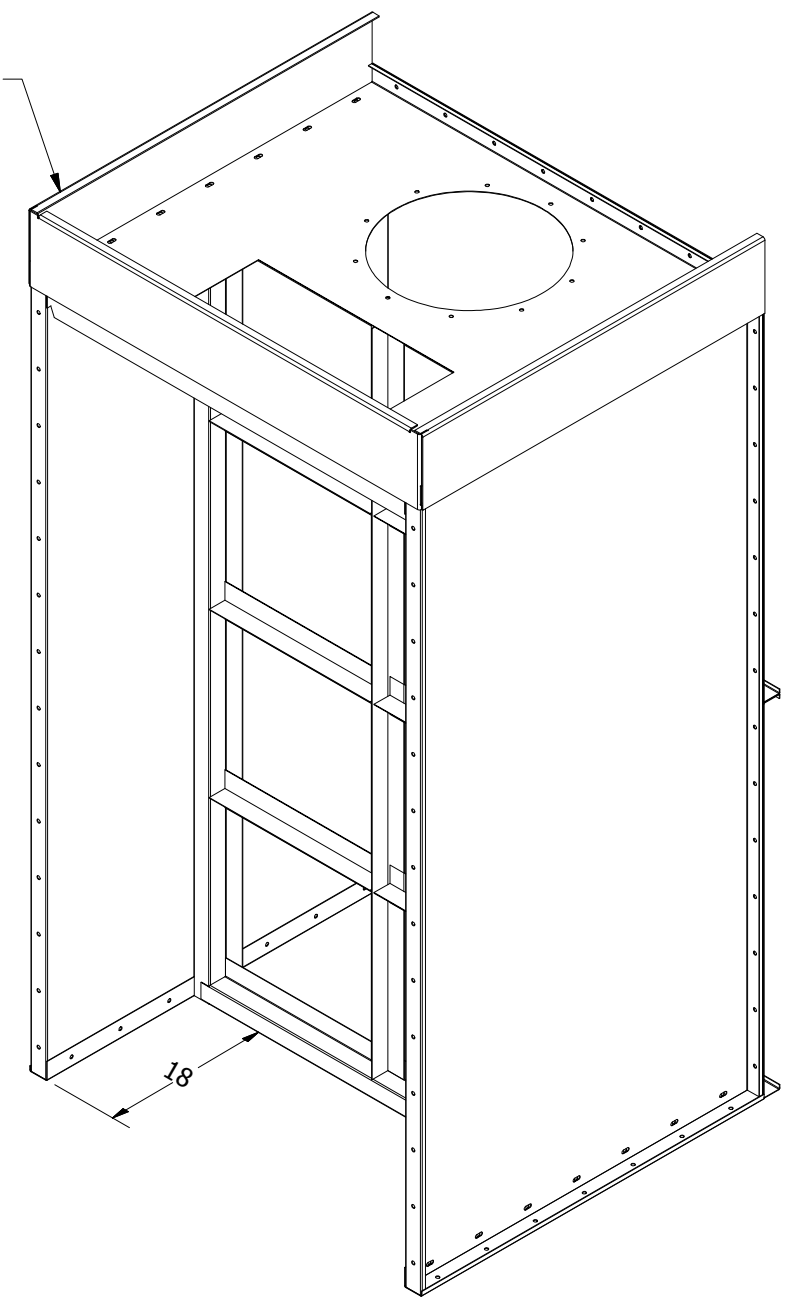

DRAWN TCOOK	3/1/2016	JC METAL FABRICATION		
CHECKED		TITLE		
QA		JCOFNRP4		
MFG		SIZE C	DWG NO JCOFNRP4	REV A
APPROVED		SCALE 0.07	SHEET 1 OF 2	

PARTS LIST		
ITEM	QTY	PART NUMBER
1	1	42 X 48
2	1	44 X 48
3	1	42 X 48 FAN AND LIGHT
4	4	42 TRIM
5	2	HORIZONTAL PLENUM
6	2	VERTICAL PLENUM
7	6	19.75 DIVIDER
8	1	79.75 DIVIDER
9	1	FIRE GAURD
10	2	42 X 84
11	1	FRONT GUARD
12	2	SIDE GUARD

EXAMPLE OF PLENUM  
GRID WORK INTERSECTION

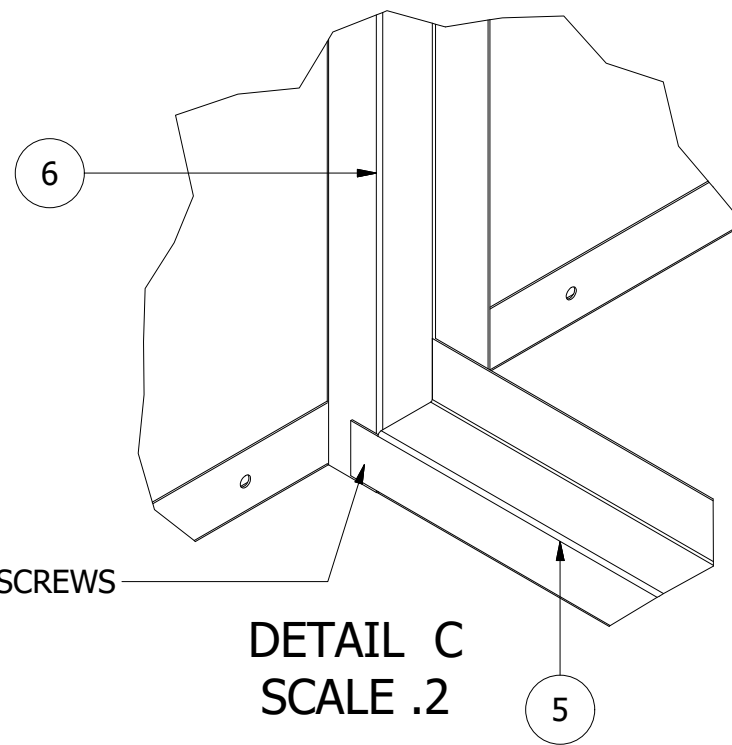

FASTEN USING SELF DRILLING SCREWS

DETAIL C  
SCALE .2

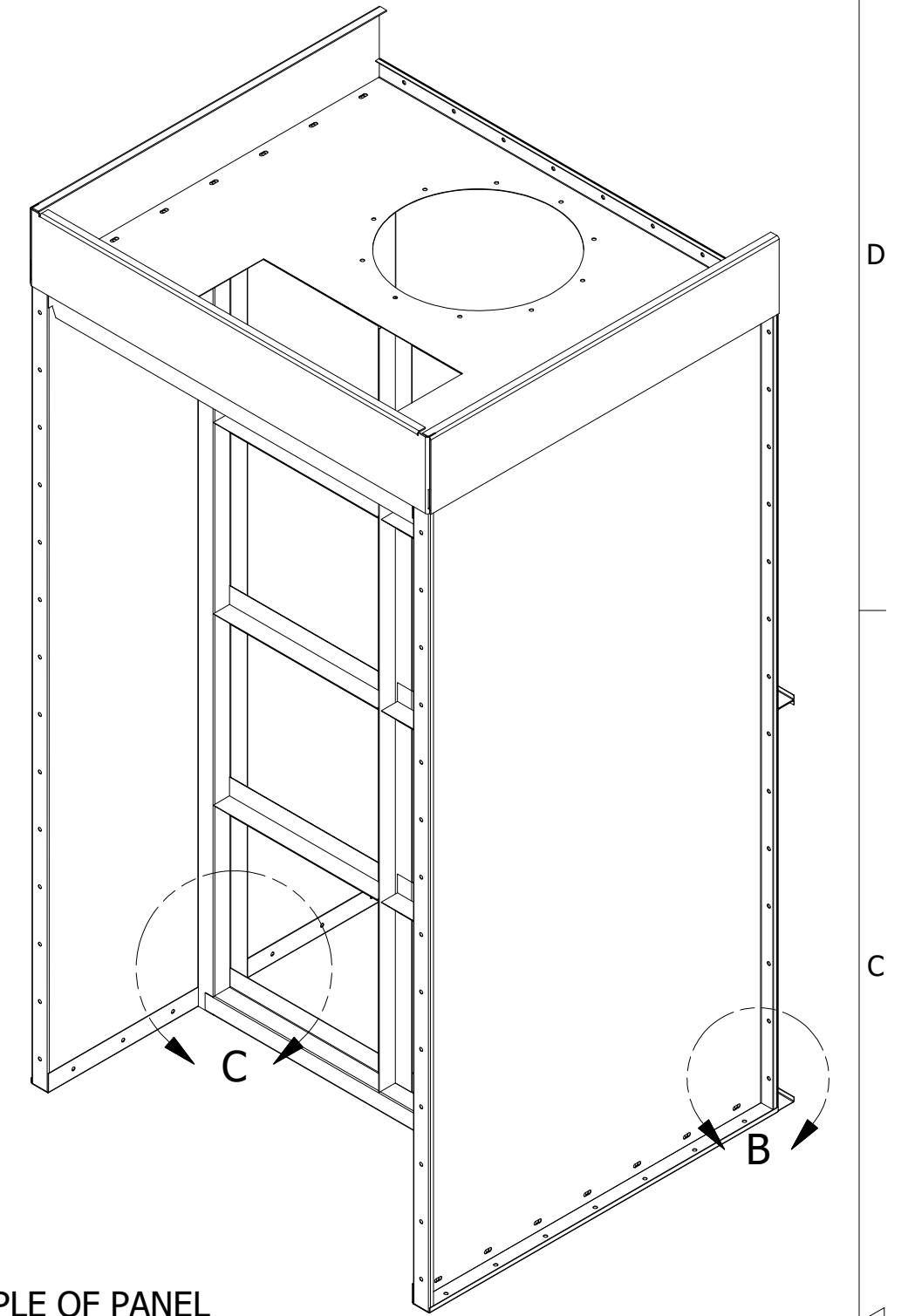

EXAMPLE OF PANEL  
INTERSECTION

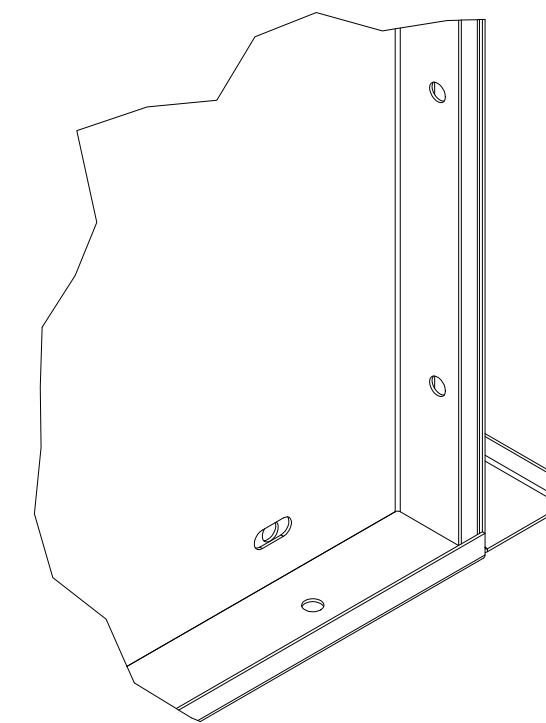

DETAIL B  
SCALE 5/16

REAR

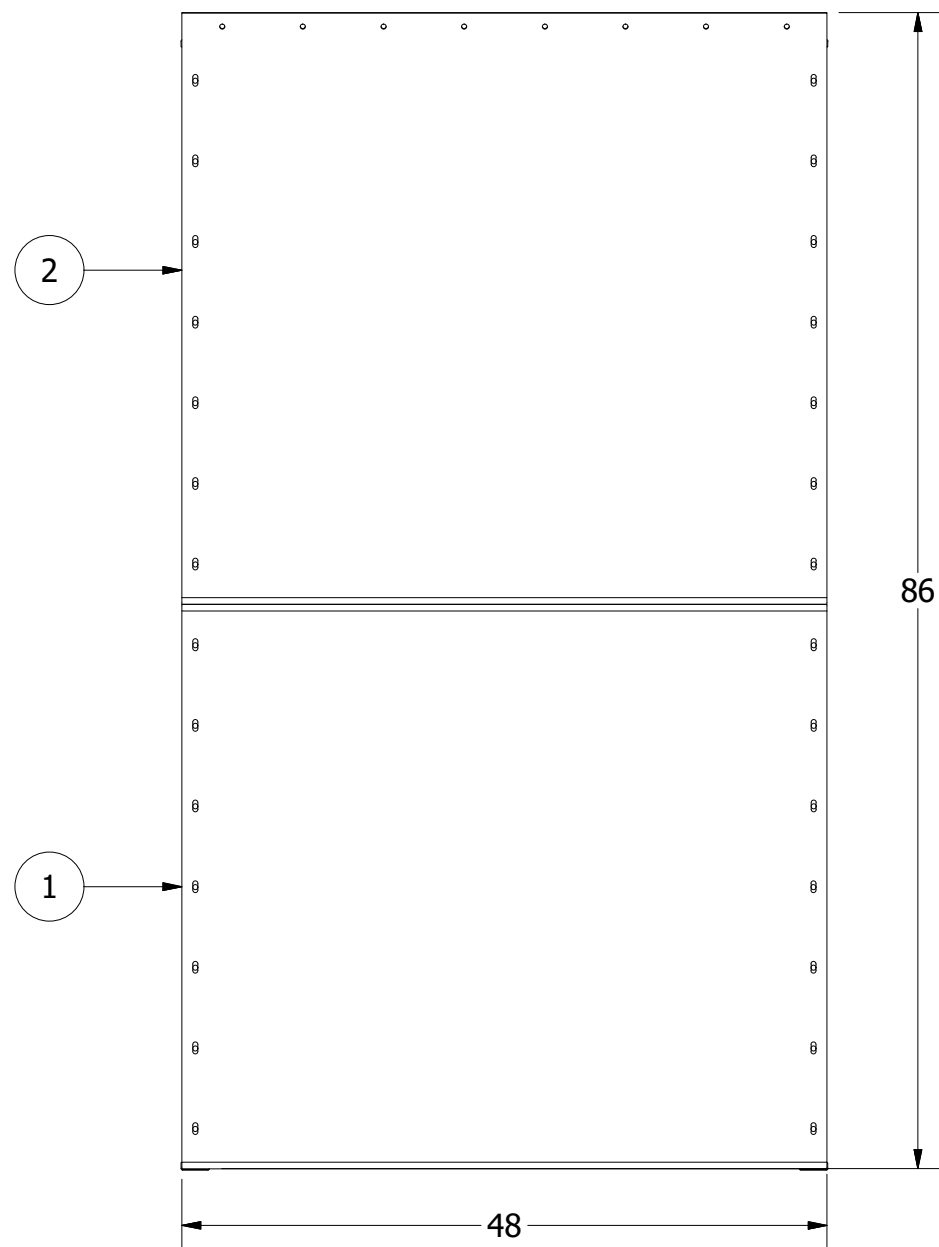

LEFT

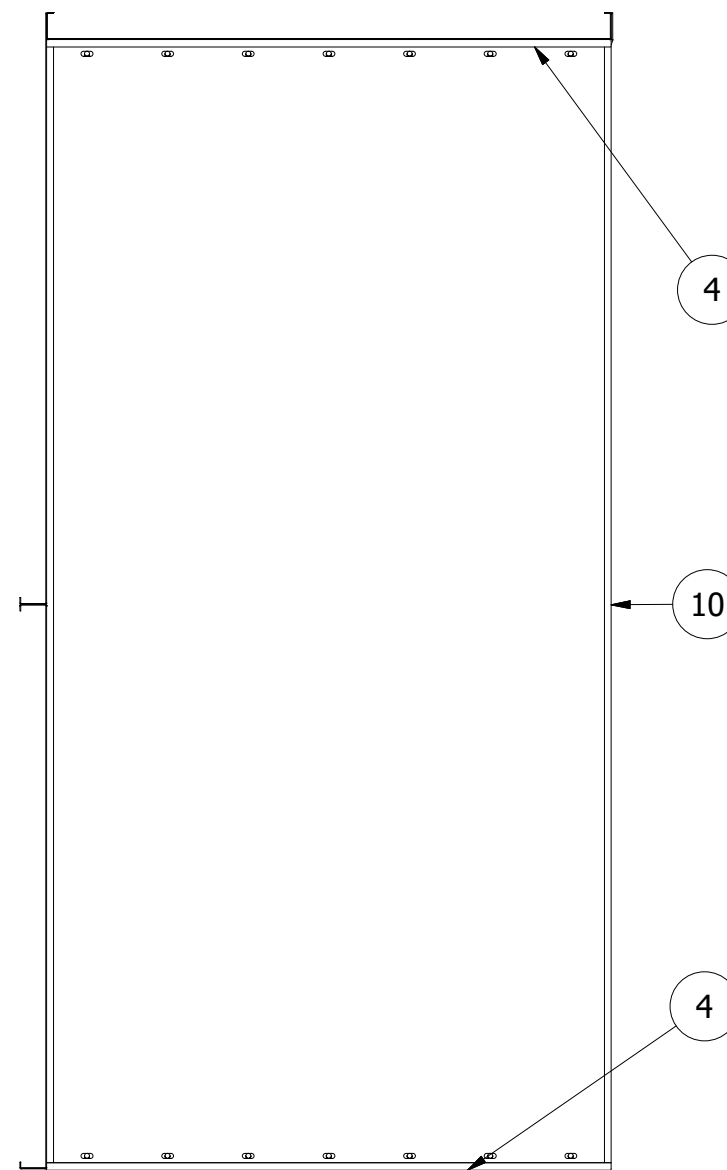

DRAWN TCOOK	3/1/2016	JC METAL FABRICATION		
CHECKED		TITLE		
QA		JCOFNRP4		
MFG		SIZE C	DWG NO JCOFNRP4	REV A
APPROVED		SCALE 0.07	SHEET 2 OF 2	